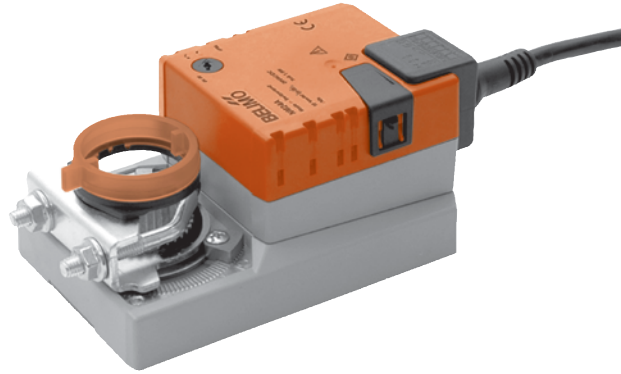

Damper actuator for operating air control dampers in ventilation and air-conditioning systems for building services installations

- For air control dampers up to approx. 2 m²
- Torque 10 Nm
- Nominal voltage AC 100 ... 240 V
- Control: Open-close or 3-point

Technical data

Electrical data	Nominal voltage	AC 100 ... 240 V, 50/60 Hz
	Nominal voltage range	AC 85 ... 265 V
	Power consumption	In operation 2.5 W @ nominal torque At rest 0.6 W For wire sizing 6 VA
	Connection	Cable 1 m, 3 x 0.75 mm ²
Functional data	Torque (nominal torque)	Min. 10 Nm @ nominal voltage
	Direction of rotation	Reversible with switch 0 ↺ or 1 ↻
	Manual override	Gearing latch disengaged with pushbutton, self-resetting
	Angle of rotation	Max. 95°↔, limited on both sides by means of adjustable, mechanical end stops
	Running time	150 s
	Sound power level	Max. 35 dB (A)
	Position indication	Mechanical, pluggable
Safety	Protection class	II Totally insulated <input type="checkbox"/>
	Degree of protection	IP54 in any mounting position
	EMC	CE according to 89/336/EEC
	Low voltage directive	CE according to 73/23/EEC
	Mode of operation	Type 1 (to EN 60730-1)
	Ambient temperature range	-30 ... +50 °C
	Non-operating temperature	-40 ... +80 °C
	Ambient humidity range	95% r.H., non-condensating (EN 60730-1)
Maintenance	Maintenance-free	
Dimensions / Weight	Dimensions	See «Dimensions» on page 2
	Weight	Approx. 800 g

Safety notes

- The damper actuator is not allowed to be used outside the specified field of application, especially not in aircraft or any other form of air transport.
- **Caution: Power supply voltage !**
- **Assembly must be carried out by trained personnel. Any legal regulations or regulations issued by authorities must be observed during assembly.**
- The device may only be opened at the manufacturer's site. It does not contain any parts that can be replaced or repaired by the user.
- The cable must not be removed from the device.
- When calculating the required torque, the specifications supplied by the damper manufacturers (cross section, design, installation site), and the air flow conditions must be observed.
- The device contains electrical and electronic components and is not allowed to be disposed of as household refuse. All locally valid regulations and requirements must be observed.

Product features

- Simple direct mounting** Simple direct mounting on the damper spindle with a universal spindle clamp, supplied with an anti-rotation strap to prevent the actuator from rotating.
- Manual override** Manual operation is possible with the self-resetting pushbutton (the gearing latch remains disengaged as long as the pushbutton is pressed).
- Adjustable angle of rotation** Adjustable angle of rotation with mechanical end stops.
- High functional reliability** The actuator is overload-proof, requires no limit switches and automatically stops when the end stop is reached.

Accessories

	Description	Data sheet
Electrical accessories	Auxiliary switch S..A..	T2 - S..A..
	Feedback potentiometer P..A..	T2 - P..A..
Mechanical accessories	Various accessories (clamps, shaft extensions etc.)	T2 - Z-NM..A..

Electrical installation

Wiring diagrams

Note

- Caution: Power supply voltage !
- Other actuators can be connected in parallel. Please note the performance data.



Direction of rotation



Open-close control

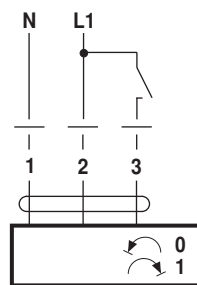

3-point control

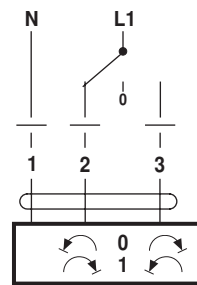

Dimensions [mm]

Dimensional drawings

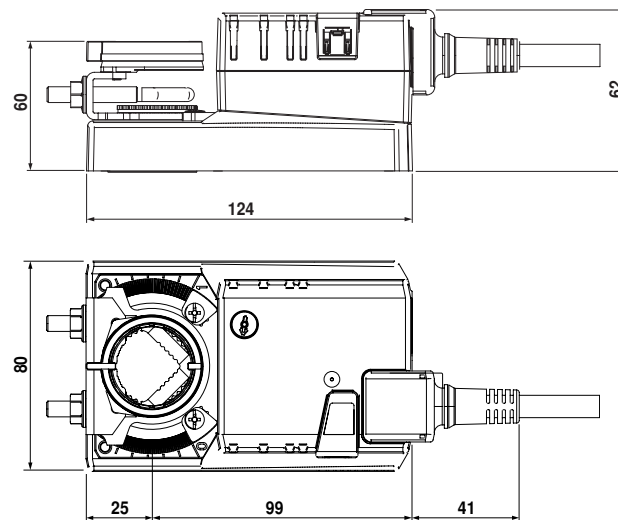

Damper spindle	Length	⊙ I ⊠
Clamp on top	min. 40	8 ... 26.7
Clamp on bottom *	min. 20	8 ... 20

* Option (Accessory K-NA)