

Damper actuator for operating air control dampers in ventilation and air-conditioning systems for building services installations

- For air control dampers up to approx. 1 m²
- Torque 5 Nm
- Nominal voltage AC/DC 24 V
- Control: Open-close or 3-point
- Damper rotation: Form-fit 8 mm

Technical data

Electrical data	Nominal voltage	AC 24 V, 50/60 Hz DC 24 V
	Nominal voltage range	AC/DC 19.2 ... 28.8 V
	Power consumption	In operation 1 W @ nominal torque At rest 0.2 W For wire sizing 2 VA
	Connection	Cable 1 m, 3 x 0.75 mm ²
Functional data	Torque (nominal torque)	Min. 5 Nm @ nominal voltage
	Direction of rotation	Reversible with switch 0 ↺ or 1 ↻
	Manual override	Gearing latch disengaged with pushbutton, self-resetting
	Angle of rotation	Max. 95° ↺, limited on both sides by means of adjustable, mechanical end stops
	Running time	150 s
	Sound power level	Max. 35 dB (A)
	Damper rotation	Form-fit 8 mm
	Position indication	Mechanical, pluggable
Safety	Protection class	III Safety extra-low voltage
	Degree of protection	IP54 in any mounting position
	EMC	CE according to 89/336/EEC
	Mode of operation	Type 1 (to EN 60730-1)
	Ambient temperature range	-30 ... +50 °C
	Non-operating temperature	-40 ... +80 °C
	Ambient humidity range	95% r.H., non-condensating (EN 60730-1)
	Maintenance	Maintenance-free
Dimensions / Weight	Dimensions	See «Dimensions» on page 2
	Weight	Approx. 480 g

Safety notes

- The damper actuator is not allowed to be used outside the specified field of application, especially in aircraft or any other form of air transport.
- Assembly must be carried out by trained personnel. Any legal regulations or regulations issued by authorities must be observed during assembly.
- The device may only be opened at the manufacturer's site. It does not contain any parts that can be replaced or repaired by the user.
- The cable must not be removed from the device.
- When calculating the required torque, the specifications supplied by the damper manufacturers (cross section, design, installation site), and the air flow conditions must be observed.
- The device contains electrical and electronic components and is not allowed to be disposed of as household refuse. All locally valid regulations and requirements must be observed.

Product features

Simple direct mounting	Simple direct mounting on the damper spindle by form-fit. The actuator, with its hollow shaft, is placed over the 8 mm square spindle of the damper and secured by two screws.
Manual override	Manual operation is possible with the self-resetting pushbutton (the gearing latch remains disengaged as long as the pushbutton is pressed).
Adjustable angle of rotation	Adjustable angle of rotation with mechanical end stops.
High functional reliability	The actuator is overload-proof, requires no limit switches and automatically stops when the end stop is reached.

Accessories

	Description	Data sheet
Electrical accessories	Auxiliary switch S..A..	T2 - S..A..
	Feedback potentiometer P..A..	T2 - P..A..
Mechanical accessories	Shaft extension AV6-20	T2 - Z-LM..A..

Electrical installation

Wiring diagrams

Notes

- Connection via safety isolating transformer.
- Other actuators can be connected in parallel. Please note the performance data.



Direction of rotation



Open-close control

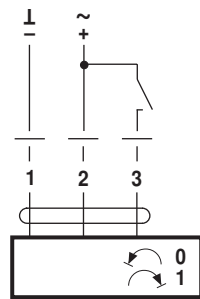

3-point control

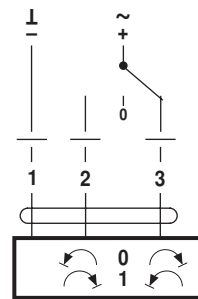

Dimensions [mm]

Dimensional drawings

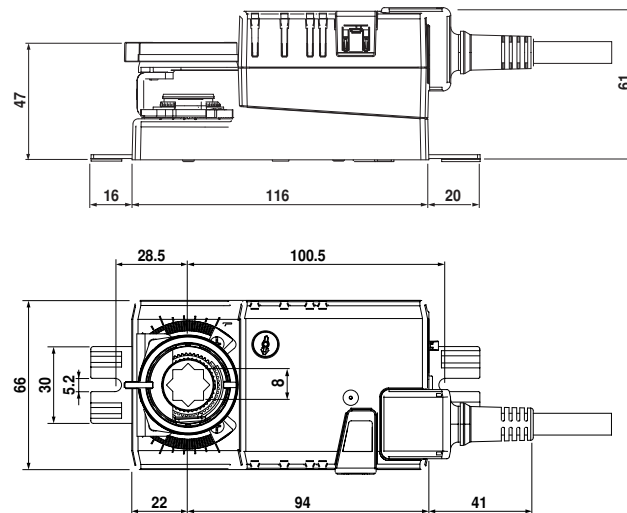

Damper spindle	Length
	min. 20