

Damper actuator for operating air control dampers in ventilation and air-conditioning systems for building services installations

- For air control dampers up to approx. 1 m<sup>2</sup>
- Torque 5 Nm
- Nominal voltage AC 100 ... 240 V
- Control: Open-close or 3-point
- Damper rotation: Form-fit 8 mm

**Technical data**

<b>Electrical data</b>	Nominal voltage	AC 100 ... 240 V, 50/60 Hz
	Nominal voltage range	AC 85 ... 265 V
	Power consumption	In operation 1.5 W @ nominal torque At rest 0.4 W For wire sizing 4 VA
	Connection	Cable 1 m, 3 x 0.75 mm <sup>2</sup>
<b>Functional data</b>	Torque (nominal torque)	Min. 5 Nm @ nominal voltage
	Direction of rotation	Reversible with switch 0 ↺ or 1 ↻
	Manual override	Gearing latch disengaged with pushbutton, self-resetting
	Angle of rotation	Max. 95° ↔, limited on both sides by means of adjustable, mechanical end stops
	Running time	150 s
	Sound power level	Max. 35 dB (A)
	Damper rotation	Form-fit 8 mm
	Position indication	Mechanical, pluggable
<b>Safety</b>	Protection class	II Totally insulated <input type="checkbox"/>
	Degree of protection	IP54 in any mounting position
	EMC	CE according to 89/336/EEC
	Low voltage directive	CE according to 73/23/EEC
	Mode of operation	Type 1 (to EN 60730-1)
	Ambient temperature range	-30 ... +50 °C
	Non-operating temperature	-40 ... +80 °C
	Ambient humidity range	95% r.H., non-condensating (EN 60730-1)
<b>Dimensions / Weight</b>	Maintenance	Maintenance-free
	Dimensions	See «Dimensions» on page 2
	Weight	Approx. 480 g

**Safety notes**

- The damper actuator is not allowed to be used outside the specified field of application, especially not in aircraft or any other form of air transport.
- **Caution: Power supply voltage !**
- **Assembly must be carried out by trained personnel. Any legal regulations or regulations issued by authorities must be observed during assembly.**
- The device may only be opened at the manufacturer's site. It does not contain any parts that can be replaced or repaired by the user.
- The cable must not be removed from the device.
- When calculating the required torque, the specifications supplied by the damper manufacturers (cross section, design, installation site), and the air flow conditions must be observed.
- The device contains electrical and electronic components and is not allowed to be disposed of as household refuse. All locally valid regulations and requirements must be observed.

**Product features**

- Simple direct mounting** Simple direct mounting on the damper spindle by form-fit. The actuator, with its hollow shaft, is placed over the 8 mm square spindle of the damper and secured by two screws.
- Manual override** Manual operation is possible with the self-resetting pushbutton (the gearing latch remains disengaged as long as the pushbutton is pressed).
- Adjustable angle of rotation** Adjustable angle of rotation with mechanical end stops.
- High functional reliability** The actuator is overload-proof, requires no limit switches and automatically stops when the end stop is reached.

**Accessories**

	Description	Data sheet
<b>Electrical accessories</b>	Auxiliary switch S..A..	T2 - S..A..
	Feedback potentiometer P..A..	T2 - P..A..
<b>Mechanical accessories</b>	Shaft extension AV6-20	T2 - Z-LM..A..

**Electrical installation**

**Wiring diagrams**

**Note**

- Caution: Power supply voltage !
- Other actuators can be connected in parallel. Please note the performance data.



Direction of rotation



**Open-close control**

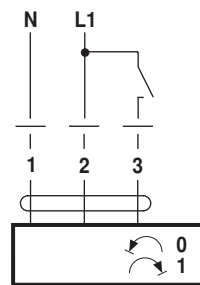

**3-point control**

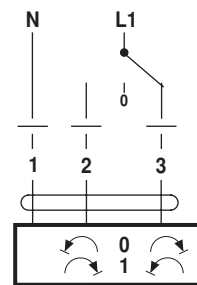

**Dimensions [mm]**

**Dimensional drawings**

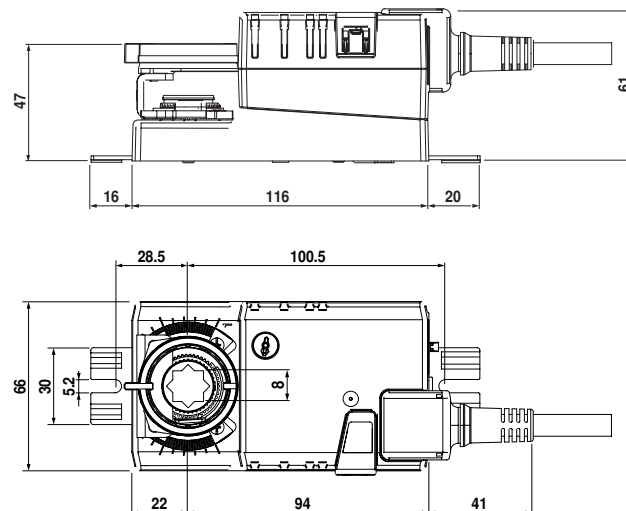

Damper spindle	Length
	min. 20