



Dampers up to approx. 3 m²
Open/Close actuator (AC 230 V)
Manual operation with integral position stop

Versatile applications

The AF... spring return actuators are intended for the operation of air dampers that perform safety functions (e.g. frost and smoke protection, hygiene, etc.).

Improved functional safety

The AF 230 actuator moves the damper to its normal working position while tensioning the return spring at the same time. If the power supply is interrupted, the energy stored in the spring moves the damper back to its safe position. The actuator is overload proof, needs no limit switches and halts automatically at the end stop.

Variable end switch

The AF230-S actuator has one fixed auxiliary switch and one adjustable auxiliary switch which allows angle of rotation of 5% and between 28...94% to be signalled.

Simple installation and commissioning

The actuator is fitted with a universal spindle clamp for quick and easy mounting directly onto the damper spindle. The actuator is also supplied with an anti-rotation strap for fixing it in position. The damper can be operated manually and fixed in any required position. Release of the locking mechanism can be achieved manually or automatically by applying the supply voltage.

Mechanical accessories

ZG-AF Damper linkage kit, page 9

Mounting instructions, page 10

Important

Read the notes about the use and torque requirements of the damper actuators on page 3.

Dimensions

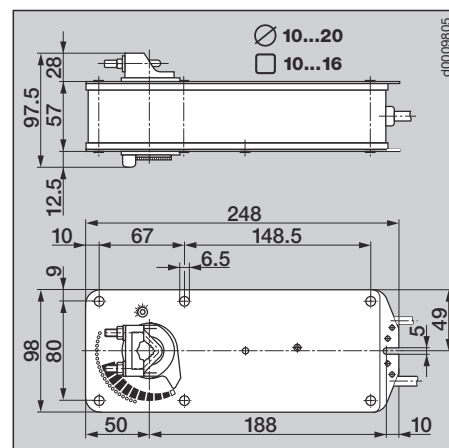

Wiring diagram

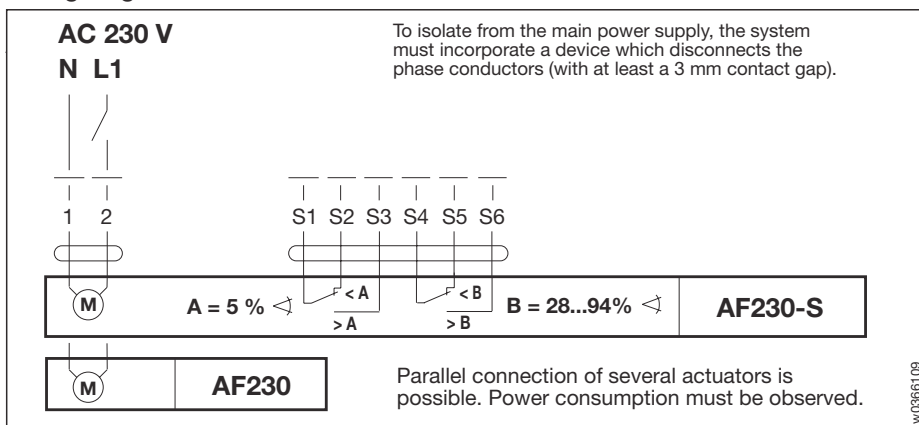

Technical data	AF230, AF230-S
Nominal voltage	AC 230 V 50/60 Hz
Nominal voltage range	AC 198...264 V
For wire sizing	11 VA
Power consumption	
- motoring	6.5 W
- holding	2.5 W
Connecting cable	- motor 1 m long, 2×0.75 mm ² - auxiliary switches (AF...-S) 1 m long, 6×0.75 mm ²
Auxiliary switch (AF...-S)	2×SPDT 6 (3) A, AC 250 V <input type="checkbox"/>
- Switching points	fixed 5% \sphericalangle , adjustable 28...94% \sphericalangle
Direction of rotation	selected by mounting L/R
Torque	- motor min. 15 Nm (at rated voltage) - spring return min. 15 Nm
Angle of rotation	max. 95° (adjustable from 33% in 5.5% steps \sphericalangle with a supplied limit stop)
Running time	motor \approx 150 s, spring return \approx 16 s
Sound power level	motor max. 45 dB(A), spring \approx 62 dB(A)
Service life	\approx 60 000 operations
Position indication	mechanical
Protection class	II (all insulated)
Degree of protection	IP 54
Ambient temp. range	-30... +50 °C
Non-operating temp.	-40... +80 °C
Humidity test	to EN 60730-1
EMC	CE according to 89/336/EEC
Low Voltage Directive	CE according to 73/23/EEC
Maintenance	maintenance free
Weight	3000 g